



The Government of the Northwest Territories (GNWT) is requesting quotations from qualified Contractors for the establishment of nonexclusive Standing Offer Agreements for **AIRCRAFT SERVICES** in support of Environment and Natural Resources in accordance with the terms and conditions attached.

Contractors should examine the documents carefully. Providing false or misleading information, or failure to complete any clause, answer any question, provide information as required, and return the required documentation MAY result in your offer being rejected as non-responsive and the GNWT may decline to enter into a Standing Offer Agreement for the purposes contemplated.

INSTRUCTIONS

1. In order to be considered, offers should:
 - have the reference number clearly marked on the outside of the envelope or package.
 - The envelope or package should be marked as confidential.
 - be received at:

Environment and Natural Resources
Forest Management Division, Aviation Services
Government of the Northwest Territories
PO Box 7
FORT SMITH, NT X0E 0P0
Telephone: (867) 872-7700 Facsimile: (867) 872-2148

- and received on or before March 31, 2011 at 17:00 hours local time. Late Offers may be rejected.

2. All questions are to be directed to:

Duane Sinclair Manager, Aviation Services Telephone: (867) 872-7719 Email: duane_sinclair@gov.nt.ca	OR	Wendy Pennycook Aviation Services Admin. Supervisor Telephone: (867) 872-7720 Email: wendy_pennycook@gov.nt.ca
--	-----------	---

3. All Standing Offers shall remain valid and open for acceptance by the GNWT by way of individual contract document for the full term of the Standing Offer Agreement as detailed herein.
4. The lowest prices offered will not necessarily be accepted. The GNWT reserves the right to cancel this request, in whole or in part, at any time and to reissue same thereafter, for any reason whatsoever, without incurring any liability and no bidder will have any claim against the GNWT as a consequence.
5. The GNWT will not be held responsible for any offer, which is not properly identified, on the outside of the submitted envelope or package.

6. FACSIMILE OFFERS WILL BE ACCEPTED in accordance with the following conditions:

- Transmissions should be faxed on or before March 31, 2011 at 17:00 hours local time. Late Offers may be rejected.
- Transmissions must be sent only to the facsimile number identified on the Request.
- The Contractor has the obligation to confirm with the recipient that the transmission has been received.
- While the GNWT will undertake to handle incoming facsimiles in a secure manner, it is impossible to guarantee the confidentiality of information contained therein.
- The GNWT shall not be held liable for any claim, demand or other actions for any reason should a facsimile transmission be interrupted, not received in its entirety, received after stated closing time and date, received by any other facsimile unit other than that stated herein or received at any other location.

7. The GNWT purchases are made on a tax-free (zero rated) basis in accordance with the following certification:

The GNWT certifies that the property and services purchased by the GNWT from the Contractor are being purchased with government funds and are not, therefore, subject to the Goods and Services Tax (the G.S.T.).

Even though the Contractor will not charge G.S.T., the contractor may be eligible to receive input tax credits with respect to any G.S.T. liability incurred by the Contractor in providing the property and services if such a refund would be available in other circumstances.

It is the sole responsibility of the Contractor to determine if input tax credits are available in respect to the provision of property and services to the GNWT. The GNWT will not compensate the Contractor for any G.S.T. liability incurred in the provision of property and services to the GNWT.

8. Verbal responses to any inquiry cannot be relied upon and are not to be construed as an implied term of this request or any resultant contract.**9. Offers shall be opened as soon as practicable after the closing time.****10. One of the priorities of the GNWT is to ensure local and northern materials, equipment and labour are used to the fullest extent practical on any GNWT contract. Therefore, the Business Incentive Policy, 63.02 applies. The Local tender adjustment of 5% will not be applied to Air Charters as per the BIP Interpretive Bulletin # 6. Contractors can obtain information on the GNWT Business Incentive Policy from the web site:**

<http://www.itl.gov.nt.ca/iea/bip/index.htm> or the BIP Monitoring Office at 867-873-7215 or 867-920-3182.

11. It will be a term of this contract that the provisions of the GNWT's Workplace Conflict Resolution Policy are applicable to and govern the relations between the contractor and its employees, agents and representatives and any employee of the GNWT for the term of the contract. A copy of the *Workplace Conflict Resolution Policy* can be found at the following website:

<http://www.hr.gov.nt.ca/policy/documents/Workplaceconflictresolutionpolicy.pdf>

Further, it will be a term of this contract that the Contractor shall, upon the request of the GNWT, remove from any GNWT work site where the contract work is being performed, any person employed by it for purposes of the contract who, in the opinion of the GNWT, had violated the Workplace Conflict Resolution Policy, and the Contractor shall not permit a person who has been removed to return to the work site.



OFFER - ROTARY WING AIRCRAFT

The undersigned (herein the "Contractor") hereby offers to the Government of the Northwest Territories (herein the "GNWT") services set out herein, under all attached Terms and Conditions and for the prices as set out in this offer. In addition to price, all terms and conditions in the attached Specific SOA Terms and General Conditions sections shall apply to any individual contract that is formed.

The prices set out herein shall be firm for the duration of the Standing Offer Agreement, namely commencing on the 2nd day of April 2011 and terminating on the 1st day of April 2012.

Table with 4 columns: AIRCRAFT TYPE, RATE PER HOUR, RATE PER HOUR (For Initial Purchase Orders OVER 39 hours), Double Crew Rate (per day). All cells contain '\$'.

All rates and fees provided by any Contractor are strictly confidential and will not be divulged to any other Contractor.

CONTRACTOR:

Form with fields for Company Name, Address, Contact, Phone, Fax, Email, Authorized Signature, Title, and Date.



OFFER - FIXED WING AIRCRAFT

The undersigned (herein the "Contractor") hereby offers to the Government of the Northwest Territories (herein the "GNWT") services set out herein, under all attached Terms and Conditions and for the prices as set out in this offer. In addition to price, all terms and conditions in the attached Specific SOA Terms and General Conditions sections shall apply to any individual contract that is formed.

The prices set out herein shall be firm for the duration of the Standing Offer Agreement, namely commencing on the 2nd day of April 2011 and terminating on the 1st day of April 2012.

Table with 9 columns: AIRCRAFT TYPE, Config. i.e., floats, RATE PER MILE, RATE PER HOUR, Rate per Hour (for contracts over 39 hours), DAILY MINIMUM (rate per day), HOLD COST (per hour), MINIMUM FLIGHT (min. leg), Free Time. All rate cells contain a dollar sign (\$).

All rates and fees provided by any Contractor are strictly confidential and will not be divulged to any other Contractor.

CONTRACTOR:

Contractor information form with fields for Company Name, Address, Contact, Phone, Fax, Email, Authorized Signature, Title, and Date.



CONFIDENTIAL PILOT INFORMATION FORM

Please ensure the following form is completed for **every** pilot either new or experienced who will be representing your company in this nonexclusive standing offer agreement.

FIXED WING
CONFIDENTIAL PILOT INFORMATION

Last Name: <small>(Print)</small>	First Name:	Employer:
Pilot Licence #:	Engineer Licence #:	Date(s) Licence(s) Issued:

LICENCE DATA

TYPE		
Airline Transport:	Commercial:	Other Licences held:
ENDORSEMENTS		
Floats:	Multi engine:	Night:
Skis:	IFR:	VFR:
Other endorsements:		

FLYING EXPERIENCE

AIRCRAFT TYPE BY MAKE/MODEL <small>i.e.: Cessna 210/Beech 99</small>	TOTAL HOURS	PIC HOURS	FLOATS (hours)	SKIS (hours)	PPC DATE	Geographic Area of Operation (Indicate any Arctic Experience)
TOTAL						

Training Received and Other Experience (DATE you received training (month/year) and experience (hours))

	Date	Hrs.	External Load	Date	Hrs.	Wildlife Survey	Date	Hrs.	Aerial Survey	Date	Hrs.
	Mountain Flying										
*Low Level Flying											

* LOW LEVEL FLYING: would include activities such as Aerial Spraying and Aerial Inspection.

DECLARATION: I certify that the information entered on this form is true to the best of my knowledge and belief.

Pilot's Signature

Date

THIS SECTION TO BE FILLED OUT BY EMPLOYER:

To the best of my knowledge, I certify that all information entered on this form to be correct. The above-named pilot has been approved by the company's chief pilot to operate the type(s) of aircraft listed and to perform all indicated specialty flying.

Name of Authorized Representative (Please Print)

TITLE

DATE

SIGNATURE OF AUTHORIZED REPRESENTATIVE

COMPANY NAME

ROTARY WING

CONFIDENTIAL PILOT INFORMATION

Last Name: <small>(Print)</small>	First Name:	Employer:
Pilot Licence #:	Engineer Licence #:	Date(s) Licence(s) Issued:

LICENCE DATA

TYPE		
Airline Transport:	Commercial:	Other Licences held:
ENDORSEMENTS		
Floats:	Multi engine:	Night:
Skis:	IFR:	VFR:
Other endorsements:		

FLYING EXPERIENCE

AIRCRAFT TYPE BY MAKE/MODEL <small>i.e.: Bell 206B/Astar 350</small>	TOTAL HOURS	PIC HOURS	FLOATS	SKIS	PPC DATE	Geographic Area of Operation <small>(Indicate any Arctic Experience)</small>
TOTAL						

Training Received and Other Experience (DATE you received training (month/year) and experience (hours))

	Date	Hrs.		Date	Hrs.		Date	Hrs.		Date	Hrs.		Date	Hrs.
Bucketing			Long-Lining			Slinging			Mountain Flying			Gun-Netting		
Infra Red Scanning			Hover Exit			Aerial Ignition			Wildlife Survey			Aerial Capture		

DECLARATION: I certify that the information entered on this form is true to the best of my knowledge and belief.

Pilot's Signature

Date

THIS SECTION TO BE FILLED OUT BY EMPLOYER:

To the best of my knowledge, I certify that all information entered on this form to be correct. The above-named pilot has been approved by the company's chief pilot to operate the type(s) of aircraft listed and to perform all indicated specialty flying.

Name of Authorized Representative (Please Print)

TITLE

DATE

SIGNATURE OF AUTHORIZED REPRESENTATIVE

COMPANY NAME



SPECIFIC SOA TERMS

The terms and conditions contained herein shall apply to any individual contract that is formed.

1. This type of unilateral contract is commonly referred to as a Standing Offer Agreement (SOA). The Contractor agrees to provide the services required at prices and on terms as agreed, but the GNWT is not bound to purchase any services whatsoever.
2. Technical and operational information may be requested from time to time by the GNWT. Replies to such requests are mandatory. This information must be provided within a reasonable period to avoid possible suspension of aircraft type, pilot or termination of the Standing Offer Agreement.
3. Each Contractor shall provide upon request the Confidential Pilot Information as enclosed herein.
4. The GNWT may terminate this Standing Offer Agreement without penalty; expense or liability at any time for any reasons whatsoever upon giving written notice to this effect to the Contractor.
5. Individual contracts will be formed using the GNWT's *Air Charter Purchase Order* contract document. The terms of the Standing Offer Agreement and those contained in the GNWT standard forms shall take precedence over the Contractors published public tariff.
6. The GNWT may enter into an SOA with all responsible and responsive Contractors that have met the requirements of the GNWT and have been accepted as approved Air Carriers for the GNWT. The Contractor may be required to have their air operations inspected and approved by an Aviation Specialist designated by the GNWT before being deemed responsible and responsive. Selection of a Contractor for individual requirements shall be at the sole discretion of the GNWT personnel entering into the contract. The determining factor will be price and availability of the required aircraft type located nearest to the departure point; however, circumstances may warrant that other factors be considered.
7. The GNWT may in its discretion, increase or decrease the requirements of any contract and accordingly amend, change or extend the term of any contract by means of written notice. No period of extension shall exceed sixty (60) days unless mutually agreed.
8. The Contractor agrees and acknowledges that sections 66 and 67 of the *Financial Administration Act*, R.S.N.W.T., 1988 c.F-4, as amended, prohibits the making of guarantees and indemnities on behalf of the GNWT and that any guarantee or indemnity made in contravention of this Act is not binding on the GNWT, and cannot be enforced by the Contractor.
9. All services provided shall be in accordance with GNWT policies, directives, methods, and procedures, and under the direction of such official(s) as may from time to time be designated by the GNWT.
10. The Contractor may not assign or delegate work to be done under this Agreement or any part thereof without written consent of the GNWT. In the case of a proposed assignment or monies owing to the Contractor under this Agreement, the Contractor is aware that the assignment must be consented to in writing by the Comptroller General of the GNWT pursuant to S.69(4) of the *Financial Administration Act*, R.S.N.W.T., 1988.

11. Indemnification

The contractor shall indemnify and hold harmless the GNWT, its officers, employees, servants and agents from and against all claims, actions, causes of action, demands, costs, losses, damages, expenses, suits or other proceedings by whomever made, brought or prosecuted, in any manner based upon or related to the activities of the Contractor under this Agreement.

12. Insurance Requirements

The Contractor shall, in addition to compliance with any provision of the *Aeronautics Act*, the air carrier regulations or any tariff, at its expense, during the period of any resultant contract, without limiting its obligations or liabilities hereto, obtain and continuously carry the following insurances with limits not less than those shown.

- a) Workers' Compensation insurance covering all employees engaged in the work in accordance with the statutory requirements of the Territory or Province having jurisdiction over such employees. If the Contractor is assessed any additional levy, extra assessment or super-assessment by a Workers' Compensation Board as a result of an accident causing injury or death to an employee of the Contractor or subcontractor, or due to unsafe working conditions, then such levy or assessment shall be paid by the Contractor at its sole cost and the Contractor will not be reimbursed by the GNWT.
- b) Employer's liability insurance with limits not less than two million dollars (\$2,000,000.00) for each accidental injury to or death of the air carrier's employee(s) engaged in the work arising out of any resultant contract. If Worker's Compensation insurance exists then, in such event, the aforementioned employer's liability insurance shall not be required but the commercial general liability shall contain an endorsement providing for contingent employer's liability insurance.
- c) Motor Vehicle and/or watercraft liability insurance covering all motor vehicles and/or watercraft owned and non-owned, operated and/or licensed by the air carrier and used in the performance of any resultant contract, in an amount not less than one million dollars (\$1,000,000.00) inclusive for each occurrence or accident.

The Department of Transportation, Airports Division have additional requirements for vehicles accessing airside at GNWT airports. It is the Contractor's responsibility to be in compliance with those requirements, including obtaining motor vehicle liability insurance in an amount not less than two million dollars (\$2,000,000), with an airside access endorsement from their insurer.

- d) Commercial General Liability and or Airport Premises and Operations Liability insurance coverage in an amount not less than two million dollars (\$2,000,000.00) inclusive for each occurrence or accident for bodily injury, death and property damage, including loss of use thereof, arising out of the business operations and or occupied airport premises of any resultant contract or agreement. Such coverage shall include but not be limited to:
- i) Products and Completed Operations Liability;*
 - ii) Contractors' Protective Liability;*
 - iii) Blanket Contractual Liability;
 - iv) Broad Form Property Damage;
 - v) Personal Injury Liability;
 - vi) Cross Liability;
 - vii) Medical Payments;
 - viii) Non-owned Automobile Liability;
 - ix) Contingent Employers Liability*; and
 - x) Employees as Additional Insureds
- * Where applicable
- e) Aircraft Legal Liability insurance covering all aircraft, owned or non owned, operated and/or licensed by the Contractor and used in the operations of any resultant contract, for not less than the limits required by the *Aeronautics Act and Canadian Aviation Regulations*.
- f) The Commercial General Liability and or Airport Premises and Operations Liability and the Aircraft Liability policies shall name the GNWT and all subcontractors as additional insured, and shall extend to cover the employees of the insureds hereunder.
- g) All policies shall provide that fifteen days written notice be given to the GNWT prior to any material changes or cancellation of any such policies.
- h) The Contractor shall deposit with the GNWT, prior to the commencement of work and as requested, a certificate of insurance evidencing the insurance(s) required by any resultant contract in a form satisfactory to the GNWT and with insurance companies acceptable to the GNWT.
- i) The Contractor shall have its insurers waive subrogation rights against the GNWT and/or its employees.
- j) The foregoing provisions shall not limit the insurance coverage required by Municipal, Territorial, Provincial or Federal Law.
- k) In no event shall the GNWT be liable for the loss of or damage to, the Contractor's aircraft, equipment or property or any part thereof.
- l) The Contractor shall provide a waiver of subrogation under any Hull Insurance Coverage the Contractor maintains for hull damage in favour of the Government of the Northwest Territories with respect to services provided under any resultant contract.
- m) The Contractor shall provide, maintain and pay for any additional insurance required under this Agreement, or under any by-law, Regulation, Act, Statute or similar instrument or which the Contractor considers necessary to cover risks not otherwise contemplated by the insurance specified in these conditions. The Contractor shall be responsible for any deductibles, exclusions and/or insufficiencies of coverage relating to such policies.

13. Scope of Requirement

The aircraft will be used to conduct aerial work and/or to transport personnel, equipment and supplies for:

- Forest Fire Activities;
- Forest Management Activities;
- Forest Resources Activities;
- Wildlife Management;
- Environment and Natural Resources Activities;
- Other uses, as directed by the Director, Forest Management Division or his/her delegate.

14. Availability and Unavailability

The pilot in command shall receive and act upon instructions given by the GNWT in respect of the scheduling and operational use of the aircraft subject to the serviceability of the aircraft, and weather conditions.

If requested, the Contractor shall provide a written statement of cause when, for safety or other reasons, the Contractor temporarily suspends a flight or any portion of the specified service.

15. Communication and Navigation Equipment:

All aircraft provided for the purposes of this agreement shall be equipped with serviceable communication and navigation equipment capable of transmitting and receiving as required, and in addition, all aircraft must be equipped with a **serviceable** 406 MHZ Emergency Locator Transmitter (ELT). It is preferred that all aircraft provided by the Contractor have an Iridium-based Automated Flight Following system (AFF) with the tracking data made available to Forest Management while under hire. Data management/transfer should meet the Canadian and United States requirements. AFF specifications are set out at:

http://www.cifc.ca/images/stories/docs/1_AFF_Data_Transfer_Specifications.pdf

All equipment must conform to all GNWT specifications. The contractor must advise the GNWT immediately of any unserviceable equipment. From time to time the GNWT may require, and the Contractor shall provide, specialized communications and navigational equipment, the cost of which shall be negotiated between the parties.

16. Certificates & Authorities

- i. The contractor shall have a valid licence issued by the Canadian Transportation Agency for a Domestic Air Service.
- ii. The contractor shall have a valid Air Operator Certificate for a Domestic Air Service authorizing carriage of passengers and cargo and utilizing aircraft in one or more of the following categories, as appropriate:
 - CAR 703 – Air Taxi Operations;
 - CAR 704 – Commuter Operations;
 - CAR 705 – Airline Operations.
- iii. The contractor shall have a valid Air Operator Certificate issued pursuant to CAR 702 – Aerial Work authorizing one or more of the following types of aerial work service as appropriate:
 - Aerial inspection and surveillance;
 - Aerial photography;
 - Forest Fire Management
 - Wildlife Management
 - Aerial mapping;
 - Aerial spraying;
 - Aerial surveying;
 - External load.
- iv. The contractor must be approved by Transport Canada to carry and transport dangerous goods by air. The dangerous goods authority shall include a Permit for Equivalent Level of Safety authorizing the air operator to carry and transport dangerous goods for suppression of forest fire activity.
- v. The following operations specifications are required:
 - carriage of persons;
 - hover exit/entry (helicopter air operations)
- vi. The contractor must be registered with NWT's Workers' Compensation Board. It is the Contractors' responsibility to provide a letter of good standing from the NWT Workers' Compensation Board indicating that the contractor is an independent business, with independent WCB coverage. This letter of good standing must be provided when submitting this standing offer agreement and must be valid for the entirety of this standing offer agreement.
- vii. The Department's Aviation Services section must be given **immediate** written notice of any changes or cancellation of the above certificates and authorities.

17. Operation, Interruption or Cancellation of Flights

The Contractor shall have exclusive operational control over chartered aircraft and the contents and crew thereof. Every person who is provided with transportation on a chartered aircraft shall comply with all the terms and conditions of the carrier, and all persons and property aboard a chartered aircraft shall be subject to the authority of the pilot in charge.

The Contractor may:

- Cancel or terminate the charter or any portion of a charter at any time;
- Return to base or to the last point of landing, or
- Divert or to land at an intermediate point.

When such action is deemed by the carrier to be necessary due to unserviceability, weather, or to conditions beyond the control of the carrier.

An aircraft will be considered to be unavailable during any 24-hour period commencing at 0700 hours, local time, when the aircraft cannot, due to mechanical failure of the said aircraft, inability of the crew to perform duties including but not limited to where the crew has exceeded statutory flight and duty time limitations, or failure of specialized equipment to complete contracted assignments.

In the event of such unavailability, the daily minimum hours will not be paid and no other charges or recoverable expenses, including crew expenses, will be considered.

18. Substitution of Aircraft

- a) When, due to causes beyond the control of Contractor, the aircraft chartered is unavailable for the time the charter commences or becomes unavailable while carrying out the charter, the Contractor may furnish another aircraft of the same type or, with the consent of the GNWT, substitute any other type at the rates and charges applicable to the aircraft originally chartered except as provided below.
- b) When the substituted aircraft is capable of a larger payload than the original aircraft chartered, the payload carried in the substituted aircraft will not be greater than the payload which would have been available in the aircraft originally chartered, unless the GNWT agrees to pay the rates and charges applicable to the substituted aircraft.
- c) When the maximum payload of the substituted aircraft is smaller than the maximum payload of the original aircraft chartered, charges will be based on the rates and charges applicable to the type of substituted aircraft, except where such rates and charges are higher than those for the original aircraft chartered, in which case the rates for the original aircraft will apply.

19. Payment and Adjustment of Charges

When a charter is cancelled by the Contractor after commencement, charges will be assessed for the completed portion only:

- a) Where flights are not completed due to mechanical failure or crew casualties and the Contractor fails to arrange satisfactory alternative transportation; and

- b) In respect of any flying in an unsuccessful attempt to complete a flight required under the charter, unless the GNWT, agrees in advance; and
- c) Where charges are assessed on a mileage basis, in respect of any deviation not requested by the charterer; and
- d) Upon request of the GNWT and subject to reimbursement by the GNWT, the Contractor may pay or assume responsibility for payment of charges for and not limited to, transportation, cartage, storage, loading, and unloading, government duties and custom fees accrued on the goods to be carried pursuant to the charter.

20. Crew Expenses

The GNWT will provide or reimburse for accommodations and meals, and in addition, ground transportation between the aircraft and living quarters at the operating site when the Contractor's personnel are away from the main base to the same standards as are applicable to GNWT personnel.

21. Additional Charges for Fuel and Oil

- a) The Department will provide or reimburse for fuel and oil at cost.
- b) Payment for fuel and oil surcharges, crew expenses and incidental charges shall be based on actual costs incurred, with no allowance for overhead or profit, and subject to discretionary GNWT audit.

22. CONTINUANCE OF TERM CHARTERS

When, prior to its termination, any term charter is extended, the minimum charge (or daily minimums) for the charter will be recalculated and based on the charge, which would have applied, had the original charter included the period of the extension.

22.1 Daily Minimums

Aircraft hired on a casual basis, less than one day, **ARE NOT** compensated for daily minimums unless the aircraft is booked as such, or the accumulated waiting period charge exceeds the daily minimum.

Aircraft hired on a short-term basis, more than one day, the daily minimums are averaged.

The daily minimums are cumulative over the life of the air charter purchase order, which includes all subsequent extensions.

In the event of an unserviceable or unavailable aircraft, the daily minimum hours **WILL NOT** be paid and no others charges or recoverable expenses, including crew expenses will be considered.

In the event that the aircraft cannot fly due to weather conditions and the aircraft is at its home base, the daily minimum hours will not be paid. The daily minimums may be prorated if the aircraft was able to fly a partial day.



23. Basic Charter Charges (for term and non-term charters)

Basic Charter charges will be:

- a) **Rates per mile will apply for all point-to-point flights where flight distances are measurable** (generally fixed wing aircraft only).

Rates per hour will apply when the Contractor is providing air service for a charter engaged in operations involving flights or parts thereof where flight distances are not measurable, or when requested by the GNWT.

- i) Where applicable, the flight time should be recorded to the nearest five minutes, or to the nearest six minutes using the decimal system as follows:

0 to 02 minutes = 0.0 hour	03 to 08 minutes = 0.1 hour	09 to 14 minutes = 0.2 hour
15 to 20 minutes = 0.3 hour	21 to 26 minutes = 0.4 hour	27 to 32 minutes = 0.5 hour
33 to 38 minutes = 0.6 hour	39 to 44 minutes = 0.7 hour	45 to 50 minutes = 0.8 hour
51 to 56 minutes = 0.9 hour	57 to 60 minutes = 1.0 hour	
NO FLIGHT SHALL BE CONSIDERED TO HAVE A DURATION OF LESS THAN 0.1 HOUR.		

- ii) The flight time for fixed wing aircraft where the distances are **NOT** measurable will be the total time from the moment the aircraft first moves under its own power for the purpose of taking off until the moment it comes to rest at the end of the flight.
 - iii) The flight time for rotary wing aircraft will be the total time from the moment the helicopter first moves under its own power for the purpose of taking off until the moment it comes to rest at the end of the flight. When operations involve a continuous succession of flights, each of LESS than ten minutes duration AND the engine is NOT shut down between such flights, flying time shall be computed from the time the helicopter commences to hover for the first flight until the helicopter ceases to hover after the final landing.
- b) The charges for performing the work on the charter computed by multiplying the applicable rate per mile or hour, by the miles or hours flown performing such work, or as applicable dependent upon contractual agreement; plus,
 - c) The charges for positioning the aircraft prior to commencement of the charter work computed by multiplying the applicable rate per mile or hour by the lesser of the flight time or distance, if any, from the Contractor's base at which the chartered aircraft is shown as available nearest to the place from which the work of the charter is to be performed, or from the place at which the chartered aircraft is actually located at the time the charter is requested by the GNWT or an offer is made by the Contractor, to the place from which the work of the charter is to be performed, plus,
 - d) The charges for de-positioning the aircraft after completion of the charter work computed by multiplying the applicable rate per mile or hour by:
 - i) The lesser of the flight time or distance, if any, to return the aircraft from the place at which the work of the charter terminated to the Contractor's base nearest the place at which the work of the charter commenced; or



- ii) The flight time actually performed where the Contractor elects to position the aircraft at another base, or to position the aircraft at the point at which another charter is to commence; or to position the aircraft at the point at which the aircraft is necessarily required for the Contractor's operational reason.
 - e) The GNWT will **NOT** reimburse the Contractor for landing fees and associated charges unless prior approval is received from the GNWT.
 - f) Total flight charges payable under any resultant contract shall not exceed the Contractor's SOA daily minimum charges, times the number of days the aircraft is contracted for or, the total number of flying hours accumulated or miles logged, whichever is greater.
- 23.1 In the case of contracts for **ROTARY WING** services only, the GNWT will only pay the stated hourly rate and the following DAILY MINIMUM charges (regardless of the daily minimum submitted by the contractor):
- January, February, March, April, October, November and December – 2.0 (two) hours at the quoted dry hourly rate.
 - May and September – 3.0 (three) hours at the quoted dry hourly rate.
 - June, July and August - 4.0 (four) hours at the quoted dry hourly rate.

When under term charter, the daily minimum outlined above will be paid to all serviceable aircraft under specific contracts when flying time is less than the stated minimum for the period indicated.

24. Application of Detention Charges

- a) When the aircraft is detained beyond the SOA free detention time at the request of the GNWT, or because of delay in loading or unloading to meet the requirements of the GNWT, the detention charges shall apply.
- b) The detention charges shall not be assessed beyond the amount required to bring the revenue for a day up to the equivalent of the minimum charge per day.
- c) When daily detention charges are applicable for any day, any charges for flying on that day will be deducted from the detention charges.

25. Charges for Special Services, Equipment & Personnel

The Contractor shall be responsible for the cost of:

- Transportation of spare parts and special equipment required to service the aircraft, unless prior written approval is received from the GNWT; and,
- The cost of airtime and data transfer for satellite phone and tracking systems.

26. Liability for Delay

The Contractor will not be liable for delay either before the flight is commenced or at any time during the charter due to weather, unavailability or to conditions beyond the control of the Contractor.

27. Safety Briefing

The pilot in command of the aircraft shall provide a safety briefing in accordance with the Canadian Aviation Regulations before the flight commences.



28. Invoicing

All invoices for aircraft charters undertaken by Environment and Natural Resources are to be provided to:

Forest Management Division
Aviation Services
Government of the Northwest Territories
PO Box 7, Fort Smith, NT X0E 0P0

Invoices shall be individual for EACH Air Charter Purchase Order which includes any subsequent extensions and shall clearly state the Air Charter Purchase Order number and aircraft registration. Invoices without an Air Charter Purchase Order number will be returned to the Contractor.

Each original invoice for flying shall be supported by flight tickets or daily flight reports signed by the GNWT after each flight, showing that the service covered by the accompanied invoice has been completed in accordance with the contract.

Invoices must be separated into individual days with the applicable dates listed and by individual air charter purchase order numbers (which includes any subsequent extensions).

Flight tickets or daily flight reports are to be signed by GNWT personnel on a daily basis. All additional charges (minus GST) authorized by the GNWT, including accommodations, meals, fuel/oil and ground transportation must be indicated on the flight report. Failure to do so may result in delay or non-payment of unauthorized charges.

Each original invoice for crew expenses, fuel/oil surcharge and incidental charges shall clearly identify the nature of the charge and shall be supported by appropriate receipt vouchers. Receipts are not required for meals. If applicable, meals are to be charged at current GNWT duty travel rates. Aircrews may not claim for meals, incidentals or private accommodations while staying at GNWT facilities, bases or camps. Crew expenses, fuel, oil or other recoverable charges cannot be claimed if supplied by the GNWT.

GST is to be deducted from all crew expense and fuel/oil receipt vouchers.

The GNWT does not accept and is not liable for third party billing. Under no circumstances are crew expenses to be billed directly to the GNWT.

When invoicing for **Fixed Wing Aircraft** (excluding Air Tankers), we will **ONLY** pay the **rate per mile** for all Point-to-Point flights where the distances are measurable, and we will pay the **rate per hour** for flights or parts thereof where the flight distances are **NOT** measurable, such as detection patrols or reconnaissance/survey flights.

When paying a rate per hour, the up and down times must be recorded for EACH leg of the flight on the appropriate daily flight tickets/reports.

Invoices shall be paid twenty (20) days from date of receipt for Northern Approved contractors (as defined by the GNWT Business Incentive Policy, 63.02) and thirty (30) days from date of receipt for all other contractors.

The Contractor shall submit all invoices for services rendered or for other charges under this Agreement as above within thirty (30) days after such service was performed.

29. The Contractor shall not be required to provide services hereunder when, in the judgement of the Contractor, conditions exist which are likely to create a hazard to the flight.
30. The Contractor shall be permitted to contract for incidental traffic on GNWT charters only with prior approval of the GNWT.
31. Air Crew Conditions - General

All aircrews provided by the Contractor over the term of the work shall be subject to prior approval and acceptance of the GNWT.

The GNWT, in its sole discretion, can refuse to accept the services of any crewmember whether such refusal is reasonable or not and without providing particulars of such refusal to the contractor. The contractor will withdraw such crewmember upon written request of the GNWT. The aircraft involved shall be considered unserviceable until an acceptable aircrew is provided.

Without limiting the GNWT's sole discretion of refusal, factors for refusal may include but are not limited to the following:

Aircrews who fail to follow safe operating practices; aircrews who perform ineffectively (being consistently late, forgetting essential equipment etc.); aircrews who refuse to co-operate in the fulfilment of the project objectives, are unable or unwilling to adapt to field living conditions, or whose general performance is unsatisfactory or otherwise disruptive or detrimental to the purpose for which contracted; aircrews who are incompatible with GNWT personnel and previous aircraft accident/incident history of aircrews may be considered as a factor in refusal.

The Contractor shall replace any aircrew member exhibiting signs of fatigue.

The Contractor shall withdraw any aircrew member who fails to operate the aircraft within standards that are considered acceptable within the resource management industry.

The Contractor must provide an aircrew required for each aircraft type it operates as specified in the Contractor's Transport Canada approved Flight Operations manual.

The GNWT reserves the option of specifying a specific pilot or aircraft from any Contractor.

Aircrews working for the Department will NOT fly more than eight (8) hours in any 24 consecutive hour period (8 hours per day). The eight-hour maximum daily flight time will also include any non-departmental flying. If a pilot flies for another customer, the eight-hour limit shall be reduced accordingly, i.e., if a pilot flies two hours on another job he/she will only be allowed to fly six hours for the Department during that 24-hour period. The air carrier must advise the Department's Aviation Services section during the hiring process if the pilot had flown for another customer during the prior 24-hour period.

Aircrews working for the Department will be limited to fourteen (14) hours of duty time in any one-day (24 consecutive hour period) including any non-departmental duty time.

When, in extenuating circumstances a need exist to exceed the flight time and flight duty time limitations and rest period as specified in the Commercial Air Service Standards it will be the pilot-in-command/Air Operator's responsibility to ensure that the necessary authorizations are obtained.

32. Specific Requirements - ROTARY WING

32.1 Crew Requirements:

- a) The Contractor must provide a crew of two:

A trained and qualified pilot having the appropriate pilots licence and endorsements with the following minimum experience:

- i) medium or heavy class rotary wing - 1500 hours P.I.C. Helicopter;
- ii) intermediate class rotary wing - 1000 hours P.I.C. Helicopter;
- iii) light class - 600 hours P.I.C. helicopter;
- iv) 100 hours P.I.C. on type;
- v) one season fire fighting and water bucketing experience;
- vi) certified for hover exit operations in accordance with air carrier operations manual.

It is preferred that the pilot-in-command have received training in Pilot Decision Making (P.D.M) and Crew Resource Management (C.R.M) training within the previous three (3) years.

A trained and qualified aircraft maintenance engineer with the appropriate licences, endorsements and aircraft certification authority for the designated aircraft and engine type.

- b) The air crew will be expected to camp out at field locations and will require their own sleeping bags and other accessories (cot/foam mattress, toiletries etc.). Accommodations will be suitable for the site and season.
- c) Rotation crew must have the same qualifications.
- d) Forty-eight (48) hours prior notification of crew changes is required.
- e) As may be required from time to time, a double crew may be requested to allow increased utilization. The Contractor should indicate if he/she is prepared to provide double crewing upon request and at what cost.

32.2 Aircraft Requirements: (Casual Hire)

a) The aircraft is to be equipped with:

- i) Two (2) sets of barrel slings and two (2) cargo nets with lanyards; each set of slings to be capable to handle the sling capacity of the aircraft.
- ii) Two (2) fire bombing buckets; each bucket to be sized to the sling capacity of the aircraft. Bambi buckets are mandatory.
- iii) Main rotor upper surfaces to be painted with contrasting bands.
- iv) White or red strobe lights visible from all directions.
- v) An hour metre activated by either the collective or transmission oil pressure.
- vi) Cargo restraint nets sufficient to secure cargo in compliance with Transport Canada Regulations.
- vii) Survival equipment specified for flight in sparsely settled areas.
- viii) Shoulder harnesses are mandatory for front seat positions and rear seat positions.
- ix) Inertia reel harnesses are preferred for side facing positions.
- x) A twelve (12) volt accessory outlet for GNWT owned peripherals is preferred.
- xi) Portable refuelling equipment is required.
- xii) Dual controls must be removed when carrying passengers.

b) **Radio/Navigation equipment** (minimum requirements):

- i) One VHF-AM Transceiver; 50 kHz spacing.
- ii) One VHF-FM transceiver with a frequency range of 150 to 174 MHz with a control head provision for 20 pilot-programmable, preset simplex and semi-duplex channels and pilot programmable guard frequencies or scanning capabilities. Northern Airborne Technology (NAT) Tac Com CH-201 control head, Wulfsberg C-5000 control head and Technisonic TFM-138 transceiver or equivalent will meet these requirements. Alternate options of installing two VHF-FM transceivers each with a frequency range of 150 to 174 MHz, which can be programmed individually and monitored simultaneously and continuously, will also be acceptable. The maximum hi/low power setting on any FM radio shall not exceed ten (10) watts.
- iii) A satellite telephone system or equivalent, wired through aircraft audio panel, with external antenna is preferred.
- iv) Provision for operation of all radios and intercom through headset boom microphones by both pilot and passenger occupying front seat.



- v) One intercom:
 - a) Medium aircraft - front and three rear seats, with headsets and boom microphones.
 - b) Light/intermediate aircraft - front and all rear seat positions with headsets and boom microphones.
 - vi) Unserviceable radio equipment and accessories are to be considered as rendering the aircraft unserviceable for operational use.
 - vii) One installed Global Positioning System (GPS) Receiver.
 - viii) One Emergency Locator Transmitter (ELT). All aircraft must be equipped with a **serviceable** 406 MHZ Emergency Locator Transmitter (ELT). An unserviceable ELT will render the aircraft unserviceable for operational use.
 - ix) It is preferred that all aircraft provided by the Contractor have a "Mode C" Transponder.
 - x) It is preferred that all aircraft provided by the Contractor have an Iridium-based Automated Flight Following system (AFF) providing voice communications and data management/transfer, with the tracking data made available to Forest Management while under hire. Data management/transfer should meet the Canadian and United States requirements. AFF specifications are set out at: http://www.ciffc.ca/images/stories/docs/1_AFF_Data_Transfer_Specifications.pdf
- c) **Hover Exit:**
- MUST BE CERTIFIED FOR HOVER EXIT/ENTRY BY TRANSPORT CANADA.
- d) **Helicopter Class Definition:**
- MAXIMUM GROSS WEIGHT (INTERNAL)
- | | |
|------------------|-------------------|
| i) Light | 0-3,599 lbs. |
| ii) Intermediate | 3,600-4,999 lbs. |
| iii) Medium | 5,000-13,800 lbs. |
| iv) Heavy | Over 13,800 lbs. |



33. **Specific Requirements - FIXED WING**

33.1 Crew Requirements:

- a) The Contractor must provide the aircrew required for each of its aircraft type as specified in the Contractor's Transport Canada approved Flight Operations Manual.

The pilot-in-command shall have an appropriate pilot licence and endorsements with the minimum qualifications of:

Large Multi-Engine Aircraft (12,500 lbs and over)

- total time; 3,000 hours PIC
- total time on type; 100 hours PIC

Small Multi-Engine Aircraft (under 12,500 lbs.)

- total time; 2,000 hours PIC
- total time on type; 100 hours PIC

Single Engine Aircraft and Cessna 337

- total time; 1,000 hours PIC
- total time on type; 100 hours PIC

Float Operations

- multi-engine; 150 hours PIC float time
- single-engine; 100 hours PIC float time

Ski Operations

- multi-engine; 150 hours PIC ski time
- single-engine; 100 hours PIC ski time

It is preferred that the pilot-in-command have received training in Pilot Decision Making (P.D.M) and Crew Resource Management (C.R.M) training within the previous three (3) years.

- b) The GNWT may ask on specific contracts that the carrier provide crew with experience greater than the minimums outlined above.
- c) All aircrew assigned over the term of the work are subject to prior approval by the Department.
- d) An aircraft maintenance engineer with the appropriate licences and endorsements or a crewman may be required for aircraft positioned at work sites not routinely serviced by scheduled commercial air carriers, (i.e., fire camps, remote settlements, etc.).
- e) The air crew will be expected to camp out at field locations and will require their own sleeping bags and other accessories (cot/foam mattress, toiletries, etc.). Accommodations will be suitable for the site and season.
- f) Rotation crew must have the same qualifications.
- g) Forty-eight (48) hours prior notification of crew changes is required.

33.2 Aircraft Requirements: (Casual Hire)

- a) Each aircraft is to have the following minimum equipment.
 - i) Seats, seat belts and cargo securing equipment for rated capacity of the aircraft.
 - ii) Survival equipment specified for flight in sparsely settled areas.
 - iii) A twelve (12) volt accessory outlet for GNWT owned peripherals is preferred.
 - iv) Portable refuelling equipment is required.

- b) Communication equipment:
 - i) One VHF-AM Transceiver with a frequency range of 118 MHz to 135.975 MHz at 50 kHz spacing.
 - ii) One VHF-FM Transceiver with a frequency range of 150 MHz to 170 MHz. Transceiver must be able to operate with a headset boom microphone from both front seats of the aircraft with intercom capability between pilot and observer. Maximum power setting of FM transceiver = 10 watts. Provision for operation of all radios and intercom through headset boom microphones by both pilot and passengers occupying the front seat and two rear seats is preferred.

All casual hire fixed wing aircraft on contract with the Department must be able to communicate effectively with Regional and District offices on the Department's FM radio network. In the event that a particular aircraft does not have a permanently installed FM radio, they must have an antenna mounted on the aircraft that is electrically isolated from the aircraft fuselage to enable the temporary installation of a portable FM radio. A drawing of a recommended antenna configuration is provided in Appendix A. Installation may vary with different aircraft.

Regions will be supplied with adapters to allow the use of portable FM radios.

- iii) Unserviceable radio equipment and accessories are to be considered as rendering the aircraft unserviceable for operational use.
- iv) A satellite telephone system or equivalent, wired through aircraft audio panel, with external antenna is preferred.
- v) One installed Global Positioning System (GPS) Receiver.
- vi) One Emergency Locator Transmitter (ELT). All aircraft must be equipped with a **serviceable** 406 MHz Emergency Locator Transmitter (ELT). An unserviceable ELT will render the aircraft unserviceable for operational use.
- vii) It is preferred that all aircraft provided by the Contractor have a "Mode C" Transponder.
- viii) It is preferred that all aircraft provided by the Contractor have an Iridium-based Automated Flight Following system (AFF) providing voice communications and data management/transfer, with the tracking data made available to Forest Management while under hire. Data management/transfer should meet the Canadian and United States requirements. AFF specifications are set out at:
http://www.cifc.ca/images/stories/docs/1_AFF_Data_Transfer_Specifications.pdf

34. Aircraft Inspections

The GNWT shall monitor the Contractor's technical compliance as related to the terms, conditions and specification contained in the contract. Without limiting the rights of the GNWT the following items will also be included: inspect each aircraft, its equipment, and documents relating to the airworthiness of the aircraft, and operational documentation including flight plans or flight notification, loading records, logs and air crew log books and licences. Such inspections shall not relieve the Contractor from meeting all Transport Canada requirements or the provision of the *National Transportation Act* or the *Aeronautics Act*.

35. The Contract/Agreement and all information issued, used or disclosed in connection with the work, excluding the Contractor's information generally available to the public, are private and may be classified as to degrees of precaution necessary for their safeguarding. The Contractor shall, at all times, take all measures reasonably necessary, including those set out in any instruction issued by the GNWT for the protection of the same and any government issue.

GENERAL CONDITIONS

In addition to the terms contained on the GNWT standard contract forms and the terms and conditions contained in the Specific SOA Terms section, the following general conditions shall form part of any contract pursuant to this SOA.

1. Definitions: For the purpose of this agreement;

“GNWT” means the Government of the Northwest Territories.

“Unavailability” shall mean the circumstances of and the time when the aircraft, pilot or engineer for it, is not in condition to perform, fails to perform or is unavailable to perform as required by the Agreement. Unavailability status will continue to apply each day until the failure and unavailability is corrected.

“Written Notice” shall include properly authorized and signed facsimile transmissions.

“Prorate” shall mean to divide or assess proportionately according to an exactly calculable factor to the nearest tenth (10th).

“Air Carrier/Contractor/Air Operator” are interchangeable terms, which mean a sole proprietorship, partnership, or limited company that possesses an Operating Certificate issued by Transport Canada and a licence issued by the Canadian Transportation Agency for the aircraft contracted for by the GNWT.

“User Authority/Contract Authority” means any GNWT department, agency or employee authorized to contract for aircraft services.

“Contract” means the Agreement in the form required by the GNWT including an Air Charter Order/Service Contract entered into with the Contractor.

“Department” means the Department of Environment and Natural Resources.

2. Regulations:

In respect of services to be provided hereunder, the Contractor shall comply with the provisions of the *National Transportation Act* and the *Aeronautics Act*, and with all applicable directions, orders, rules and regulations made thereunder.

3. Sufficient Funds:

It is a condition of any resultant contract that payment is subject to Section 46 of the *Financial Administration Act*, as amended, which provides as follows:

“It is a condition of every contract that payment made by or on behalf of the government requiring an expenditure, that an expenditure pursuant to the contract will be incurred only if there is a sufficient uncommitted balance in the appropriated item for the fiscal year in which the expenditure is required under the contract.”

4. Set-Off:

The GNWT may set-off any payment due the Contractor pursuant to any resultant contract against any monies owed by the Contractor to the GNWT pursuant to any resultant contract or otherwise.

5. Default:

In the event that the Contractor is, in the opinion of the GNWT, in default in respect of any obligation hereunder the GNWT may do any act as it deems necessary to remedy such default and the GNWT may deduct or set-off the cost of such remedy against any payment due the Contractor under any resultant contract.

6. Hold Back:

The GNWT having given written notice of a breach, may withhold or hold back, in whole or in part, any payment due the Contractor without penalty, expense or liability, if in the opinion of the GNWT, the Contractor has failed to comply with or has in any way breached an obligation of the Contractor hereunder. Any such hold back shall continue until the breach has been remedied to the satisfaction of the GNWT.

7. Termination:

The GNWT may terminate any resultant contract at any time without penalty upon giving written notice to this effect to the Contractor if, in the opinion of the GNWT, the Contractor is not able to perform the services as required, the Contractor's performance of work is persistently faulty, or in the event that the Contractor becomes insolvent or commits an act of bankruptcy. Other reasons for termination of any resultant contract shall include but shall not be limited to the following: prolonged unserviceability of aircraft; aircraft fails to perform according to the manufacturer's specifications, unserviceable radios, unserviceable ELT, non-compliance with Transport Canada regulations, or by mutual agreement. Any resultant contract shall terminate as of the day for termination set out in the written notice. The Contractor shall forthwith invoice the GNWT for work performed to the date of termination.

8. Employer/Employee Relationship:

For greater certainty it is understood and agreed that nothing contained herein shall create or shall be deemed to create the relationship of either employer and employee or principal and agent between parties hereto.

9. Laws:

Any resultant contract shall be interpreted and governed in accordance with the laws of the Northwest Territories and the laws of Canada as they apply in the Northwest Territories.

10. Waiver:

It is understood and agreed that no waiver by either party of any breach of any term, condition or covenant of any resultant contract shall be effective unless the waiver is in writing and signed by both parties nor shall any such waiver be taken or held to be a waiver of any further breach of the same term, conditions or covenant.



11. Performance:

It is understood and agreed that the failure of either party at any time to require the performance of any provision or requirement of any resultant contract shall not affect the right of that party to require the subsequent performance of that provision or requirement.

12. Labour Disputes:

In the event that any actual or potential labour dispute delays or threatens to delay the timely performance of any resultant contract the Contractor agrees forthwith to give written notice of any such dispute to the GNWT and in such event the GNWT may terminate any resultant contract without penalty, expense or liability upon giving written notice to this effect to the Contractor.

13. Provisions of Contract:

It is intended that all provisions of the contract shall be fully binding and effective between the parties, but in the event that any particular provision or provisions or a part of one is found to be void, voidable or unenforceable for any reason whatsoever, then the particular provision or provisions shall be deemed severed from the remainder of this agreement and all other provisions shall remain in full force.

14. Assignment:

Any resultant contract shall enure to the benefit of, and be binding on, the respective administrators, successors and assigns of each of the parties hereto.

APPENDIX A

**RECOMMENDED ANTENNA CONFIGURATION
FIXED WING VHF ANTENNA – PORTABLE FM radio
FOREST MANAGEMENT DIVISION REQUIREMENTS - (clause 32.2(b)ii)**

FIXED WING VHF ANTENNA – Portable FM radio

Recommended retrofit for fixed wing detection patrol aircraft without VHF FM capabilities.

Whenever possible, the antenna should be mounted on the bottom of the aircraft as sketched below to maximize transmission and reception.

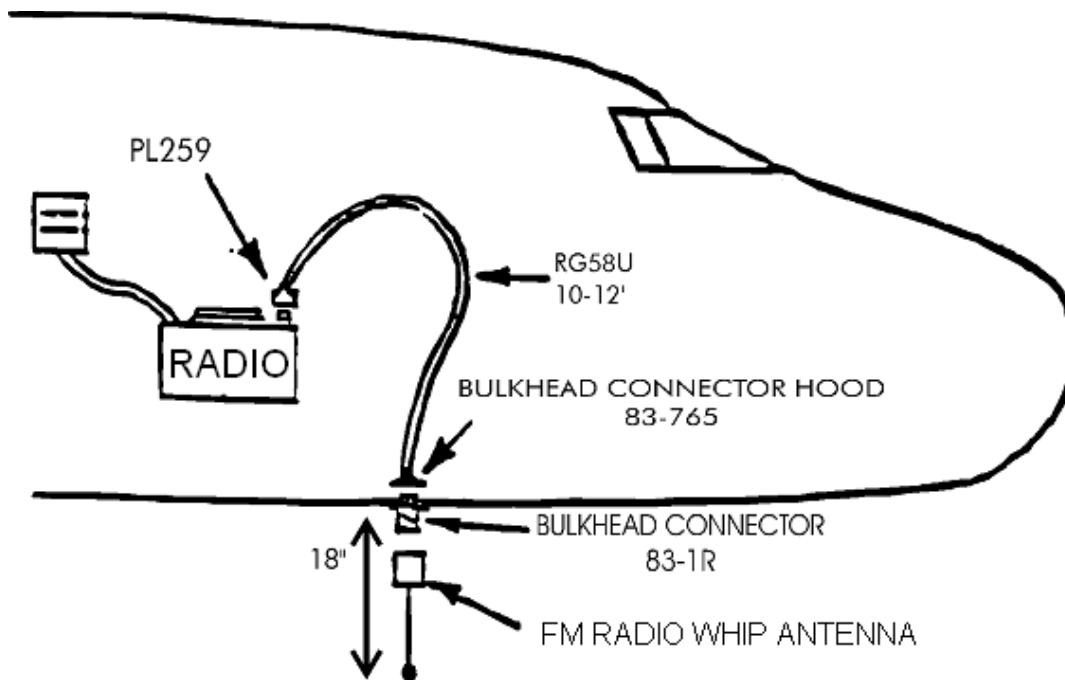

THIS HAS NOT BEEN APPROVED BY TRANSPORT CANADA.

APPENDIX A

FIXED WING VHF ANTENNA – Portable FM radio

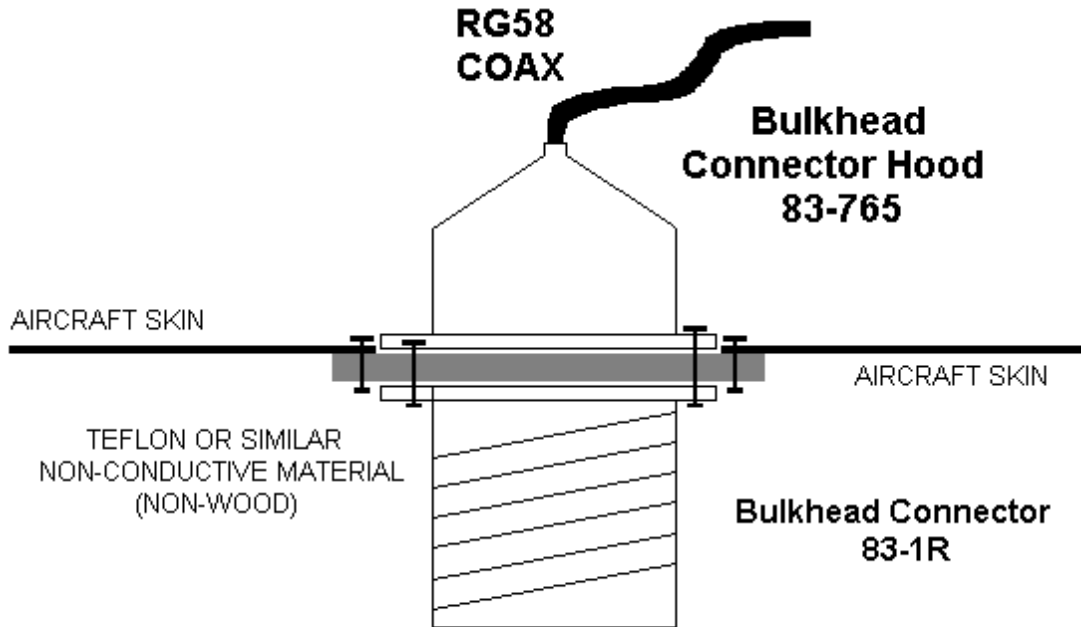

**SUGGESTED INSTALLATION ONLY!
THIS HAS NOT BEEN APPROVED BY TRANSPORT CANADA**



Meals and Incidental Expenses – October 1, 2010

The allowances for meals and incidental expenses when travelling in Canada are now:

Breakfast	\$20.95
Lunch	\$20.30
Supper	\$52.30
Incidentals	\$17.30

	\$110.85

NEW RATES MAY BE ISSUED APRIL 01, 2011

CHECK LIST OF REQUIRED DOCUMENTS

1. *CTA Licence*
(Not required - if previously submitted and there are no changes or updates and licence is still valid. Certify in writing that it is on file and current and that there no changes or updates)
2. *Transport Canada Air Operator Certificate*
Include **Operational Specifications – e.g. Entering or Leaving a Helicopter in Flight, Forest Fire Management, Aerial Surveying, authorized types of aircraft, carriage of passenger, etc.**
(Not required - if previously submitted and there are no changes or updates and certificate is still valid. Certify in writing that it is on file and current and that there no changes or updates)
3. *Rates and Signed Acceptance of Agreement*
(Page 4 or 5 of the Standing Offer Agreement)
4. *Aircraft Registration List*
(Page 6 of the Standing Offer Agreement)
5. *Current Copies of Certificates of Insurance*
(See section 12 on pages 12 and 13 of the Standing Offer Agreement regarding additional insured, providing fifteen days notice of material change and to waive subrogation rights against the GNWT)
6. *A letter of good standing with the NWT Workers' Compensation Board.*
7. *Complete and current copy of Tariff*
(Not required - if your company has already submitted a complete tariff. But, we will require any amendments or updates)
8. *Completed Pilot Information Form(s)*
(Page 8 or 9 of the Standing Offer Agreement)
9. *Certification of Dangerous Goods Approval*
Certify in writing if your company is dangerous goods approved **OR** if your company is NOT approved.
10. *Fuel Rate Sheet – FIXED WING ONLY*
(Page 10 of the Standing Offer Agreement)

PROVISION OF THESE DOCUMENTS IS MANDATORY. INCOMPLETE SUBMISSIONS WILL NOT BE ACCEPTED, WHICH MAY CAUSE DELAY IN THE REGISTRATION AND ULTIMATE USAGE OF YOUR COMPANY.